

INSTALLATION

The SUITMATE® Swimsuit Water Extractor has been designed and manufactured with safety as our primary consideration. Therefore, it is important that the unit be installed correctly. It is also important that the installation comply with all local building codes and regulations. Please consult your local licensed plumbing and electrical engineers or contractors about your installation. Read the entire INSTALLATION instructions before beginning your installation. Remember: *DO IT RIGHT* and *DO IT SAFE!*

PROPER LOCATION FOR THE SUITMATE®

Following is a list of factors to consider in determining a location for the SUITMATE®.

1. The unit should be located in an area that is near where people remove and rinse out their swimsuits.
2. The unit should NOT be located in a cluttered area or where it is exposed to direct shower water or water hose down.
3. The unit should be mounted on a wall structure that will support the unit's approximate 60 pounds hanging weight plus the added weight or pressure of people leaning on the unit. Consult the PROPER WALL MOUNTING section of these instructions to determine an appropriate location.
4. There should be a means to dispose of the wastewater from the unit. Consult the PROPER DRAINAGE section of these instructions to determine an appropriate location.
5. The unit should be wired to 115-volt (AC), 20-ampere 60Hz *dedicated circuit*. Consult the PROPER ELECTRICAL CONNECTIONS sections of these instructions to determine proper location.

PROPER WALL MOUNTING OF THE SUITMATE®

The SUITMATE® should be mounted to the wall with the Mounting Bracket that is provided with the unit. The SUITMATE® INSTALLATION DIAGRAM (page 4) shows the recommended location for the mounting holes, the electrical service, and the wastewater outlet (if utilized). The SUITMATE® Mounting Bracket must be secured to a wall stud, or to concrete block or cinder block wall.

WARNING!

Anchors in drywall are not sufficient to mount the SUITMATE®.

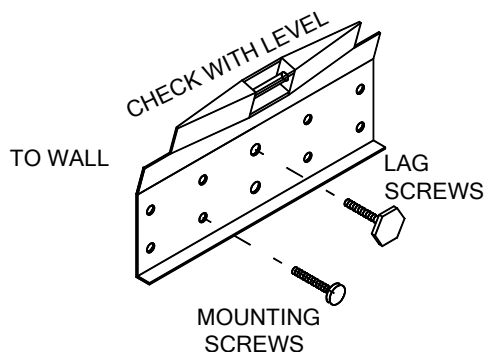

Locating and Security the Mounting Bracket to the Wall

The recommended height from the floor to the top of the SUITMATE® is 42 inches. At least an additional 10 inches of clearance above the SUITMATE® is needed for the opening and closing of the lid. This means that the top edge of the Mounting Bracket should be 39 1/5 inches from the floor. Use the SUITMATE® INSTALLATION DIAGRAM to determine a location on the wall that provides adequate clearance, a strong and secure place for the Mounting Bracket as well as easy access to electrical and drainage connections.

WARNING!

The Mounting Bracket must be level after secured to the wall.

To secure the Mounting Bracket to a stud, center the Bracket on the stud and mark on the wall or the stud the locations of the two vertical center holes of the Mounting Bracket. Drill the marked locations with a 1/8-inch drill bit. Make certain the Mounting Bracket will be level after it is secured to the wall. Reposition the Mounting Bracket over the two holes. Drill the outer two holes to receive wall anchors. Install the wall anchors.

Secure the Mounting Bracket to the stud by using two 5/16 x 2 inch lag screws through the two vertical center holes. Make certain the Bracket is level. Finish securing the Bracket with the appropriate fasteners in the outer two holes. For mounting to concrete, etc., use at least four No. 10 or larger screws fastened into appropriate anchors. After the Bracket has been anchored to the wall and the electrical and drainage requirements have been allowed for, the SUITMATE® is ready to be mounted to the wall.

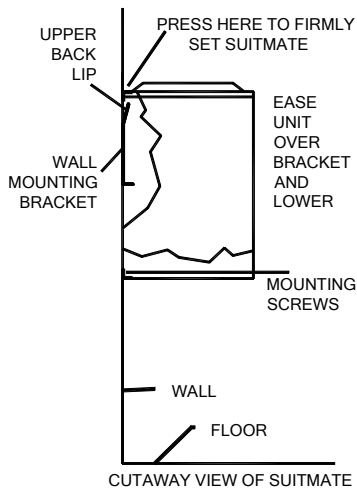

Mounting the SUITMATE® to the Wall

Remove all packaging material from the SUITMATE® including material around the Motor and the shipping board on the bottom of the unit. The upper back lip of the SUITMATE® should be lowered down and centered on the Bracket. After the unit is centered, push down on the back of the unit to make certain that it is securely wedged onto the Bracket. Make certain the unit is level. If it is not level, remove the unit, adjust the Mounting Bracket and re-hang the unit. A level installation is necessary to minimize vibration and insure proper drainage of wastewater. Finish securing the unit to the wall using appropriate fasteners and anchors on the lower mounting channel at the bottom rear of the unit. This will prevent the unit from being lifted from the Bracket or being moved.

PROPER DRAINAGE FOR THE SUITMATE®

Note: *Strictly follow all applicable local plumbing codes and regulations.*

To a Floor Drain

Drainage of the wastewater to a floor drain should be done ONLY IN an area where the floor is normally wet. DO NOT drain water across a floor where people do not expect to encounter a wet and slippery condition. SUITMATE® comes with a short flexible floor drain extension tube connected with a stainless steel hose clamp to its drain tailpiece.

WARNING!

SUITMATE® The drain tube that comes with the unit must not be removed unless the unit is connected to an approved wastewater outlet or the factory-supplied tube is replaced with another tube according to the following instructions.

Replacing the Factory Drain Tube with a Longer Drain Tube

Use a 1-1/4 inch I.D. drain tube with a smooth interior that will not crimp or collapse. Use the stainless steel hose clamp that is provided with the factory flexible floor drain extension tube to secure the replacement tube to the unit's drain tailpiece. Run the drain tube so that it is never higher than the bottom of the SUITMATE® and always slopes down. Secure the drain tube to the wall or floor with properly sized "U" clamps so it cannot be maneuvered to trap wastewater. Cut off the end of the drain tube on an angle to help prevent it from being blocked by the floor, wall, or some other object. Upon completion of the installation, check to make certain that there is a free flow of water from the drain tube extension.

To an Approved Sanitary Waste Line

This installation should only be done in accordance with all applicable local plumbing codes and regulations. The unit's 1-1/4 inch O.D. drain tailpiece is designed for connection with standard compression type plumbing fittings. There is room inside the housing for the use of a standard "P" type plumbing connection. The waste outlet should be located in the wall behind the unit. The SUITMATE® INSTALLATION TEMPLATE shows the appropriate location for the waste duct.

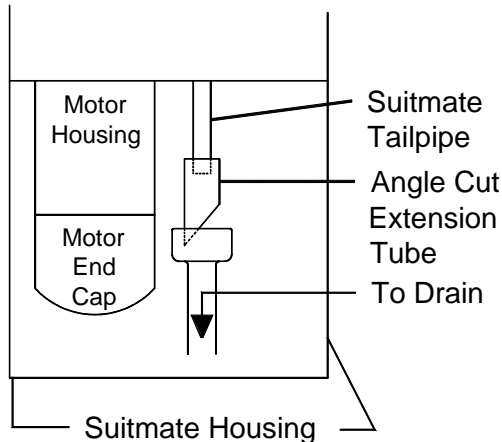

If an open-site drain connection is required and the open site is to be positioned within the SUITMATE® housing, locate the top of the receiver pipe below the top of the Motor end cap, and locate the top outer edge of the receiver pipe at least 1-1/4 inches from the body of the Motor. (See also the SUITMATE® INSTALLATION TEMPLATE.) Be certain that the cut off end of the drain extension tube is below the top of the receiver with the angle cut facing away from the Motor as illustrated.

PROPER ELECTRICAL CONNECTIONS FOR THE SUITEMATE®

Note: Strictly follow all applicable local electrical codes and regulations.

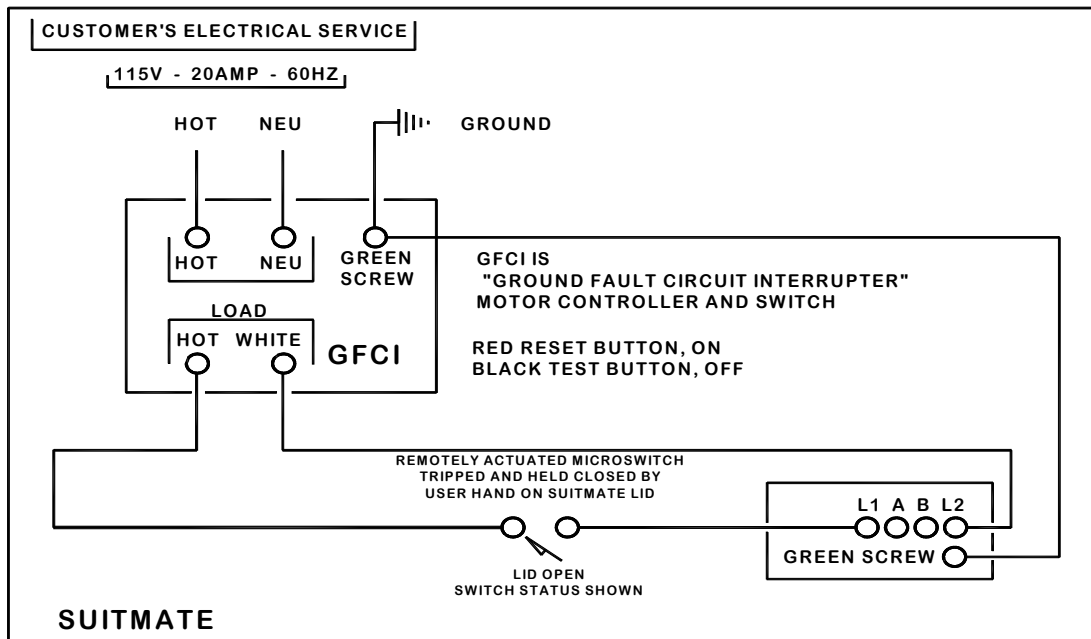

The SUITMATE®, equipped with a ground fault circuit interrupter (GFCI), which is designed to be connected to a 115 volt, 20 ampere 60 Hz *dedicated circuit* that is protected by a fuse or circuit breaker. **A PLUG-IN INSTALLATION IS NOT ACCEPTABLE!** The utilized circuit must be run to the SUITMATE® weatherproof Junction Box that contains the GFCI. A liquid tight raceway such as Ultralight® Liquid Tight Flexible Conduit (or the equivalent) should be used from

the circuit connection to the Junction Box. The SUITMATE® INSTALLATION TEMPLATE shows the location of the suggested area behind the unit for the entrance of the electrical raceway that does not interfere with the drainage connection.

WARNING!

Do not route the raceway where wastewater can flow or drip on it.

Remove the cover of the weatherproof Junction Box, which contains the GFCI, and remove the GFCI mounting screws. The circuit ground conductor must be connected to the green grounding screw located on the GFCI. If no ground is available on the circuit utilized, you **must provide** a proper ground for the SUITMATE®. The hot and neutral leads of the power circuit should be connected to the GFCI screw terminals marked "LINE". Connect the hot lead to the terminal marked "HOT" and the neutral lead to the terminal marked "WHITE". After the correct electrical connections have been properly made, remount the GFCI using the screws previously removed. Reinstall the weatherproof Junction Box cover previously removed. This cover provides access to the GFCI "TEST" and "RESET" buttons.

POSTING THE WALL SIGN

It is important that the wall sign included in the INSTALLATION PACKAGE be mounted on the wall above the unit. Locate the bottom edge of the sign six inches above the SUITMATE®. At this height the sign will not be blocked when the lid is raised. It will also serve as a stop to keep the Lid from striking the wall behind the unit.

The sign has an adhesive foam strip around the perimeter of the backside. Be certain the surface that the sign is to be mounted to is clean and dry. Without touching the sign to the wall, align the sign six inches above the unit and at its center. Press the sign to the wall and rub firmly over the adhesive portion of the sign.

TESTING AND OPERATION

After the mounting and all connections are complete, test the SUITMATE® as follows:

1. Make certain all packaging material is removed from the unit including material around the Motor and the shipping board on the bottom of the unit.
2. Check to see that the Basket is empty and that the Lid moves freely.
3. Press down on the Lid and hold down for several seconds. The unit should run smoothly and there should be no excessive vibration or noise.
4. Release and lift the Lid from the down position. The Basket should stop rotating within a second or two.
5. Test the SUITMATE® by putting a wet swimsuit in the unit according to the instructions on the underside of the Lid. If there is excessive vibration or noise it is usually caused by the improper loading of the swimsuit. Be certain that the swimsuit is pushed to the bottom of the Basket and that all material is at least two inches below the top of the Basket.

INSTALLATION TROUBLESHOOTING

If the SUITMATE® does not operate, check the following:

1. Check to see if there is power to the unit. Check the circuit using an A.C. voltmeter set to the appropriate range; measure across the "LINE" side of the GFCI.
2. Make certain that the GFCI switch is in the "ON" position. The red button must be depressed to turn on the GFCI.
3. Check the connections on the GFCI Junction Box. Be certain there is power on the "LOAD" side of the GFCI.
4. Check the SUITMATE® TROUBLESHOOTING section in this manual for additional troubleshooting assistance.

FINISHING THE INSTALLATION

Be certain to save this SUITMATE[®] MANUAL along with all the other materials included in the INSTALLATION PACKAGE envelope. If you did not receive all the materials listed or need additional information, call the Extractor Corporation at 800-553-3353. With proper installation, use, and maintenance your SUITMATE[®] Swimsuit Water Extractor will provide you with years of trouble-free service.